



HF SuperPacker Pro – 100 W Amplifier, Version 2 Operator Manual



Manual version 1.00, June 16, 2010
http://site.hfprojectsyahoo.com/hf_superpacker_pro

a) Introduction

a.1. Description

This project will provide you with an excellent source of fun, interest and skill building challenge. In the end you will have a compact 100 watt linear amplifier for use with QRP SSB/CW transmitters on the amateur bands 160 through 10 meters, which can be powered from a 12 volt DC supply. The design is a good balance between output power, physical size and battery power consumption. The completed amplifier will reward the builder with a clean, more powerful output signal from a QRP transmitter when radio conditions become marginal.

a.2. Amplifier Circuit

The amplifier module is a push-pull design, biased for Class AB linear operation and uses MRF454 type transistors (<http://www.macom.com/DataSheets/MRF454.pdf>) in its output stage. The design is based on a Communications Concept 140W Amplifier design. The Motorola Power Amplifier is described in a Motorola Application Note from 1993 called Linear Amplifiers for Mobile Operation, listed as AN762 (<http://download.prgm.org/boxfiles/technik/an762rev0.pdf>). Each MRF454 is specified for a power output of 80 W CW. The maximum dissipation is 250 Watts, and the maximum continuous collector current is 20A.

a.3. Instrumentation

The HF SuperPacker Pro uses a fan-cooled heat sink to dissipate excess heat away from the transistors. A temperature sensor on the heat sink (U5) and a current sensor on the +12 volts going to the transistors report these critical parameters back to the PIC microcontroller analog inputs. The MPU-100 module U2 chip, receives all of the status information, controls all of the operations, and interacts with the user. Two digital signals come from the Carrier Sensor. One of these simply indicates when RF enters the amplifier and is used by the PIC to trigger the T/R relays. The external PTT input acts in parallel with this digital signal and thus has the same effect on the PIC. The other digital signal is a square wave at exactly one-fourth the frequency of the RF input. This signal is used by the PIC to calculate the frequency and select the proper low pass filter. In addition to digital input signals, the PIC Microcontroller module receives six different analog signals that monitor important parameters of amplifier operation.

a.4. Specifications

Dimensions (inch) Overall:	5.5 Deep x 7.0 Width x 2.8 High
Weight (lbs):	3
DC Power:	13.8 VDC 20A max. Reverse-Polarity
Protection. Power Pole connectors	
Filters Auto selection:	160-10 meters. Sized for 100W operation

Control: display	Shaft Encoder with 1x16 LCD back-lit
Input Drive: protection	Menu choice of 2.5 or 5W. Overdrive
Monitoring: Voltage, Frequency	In power, Out power, SWR, Temperature,
Adjustments:	VOX, PTT
Indicators:	LED Power, TX, Overdrive
Duty Cycle: fan	Continuous, Computer Controlled, Internal
Spurious Products:	-40 dB or better @ 100 watts
RF Control:	RF Sensing or PTT T-R Relay
Modes:	SSB, CW, PSK
Power Transistors:	MRF454
Circuitry:	Class AB, Push Pull
Construction: silkscreens, all circuit boards and parts	Vented aluminum enclosure, painted panels,

a.5. Block Diagram

The block diagram on the page following will give you a rough guide to the system configuration of this project:

SuperPacker Pro Block Diagram

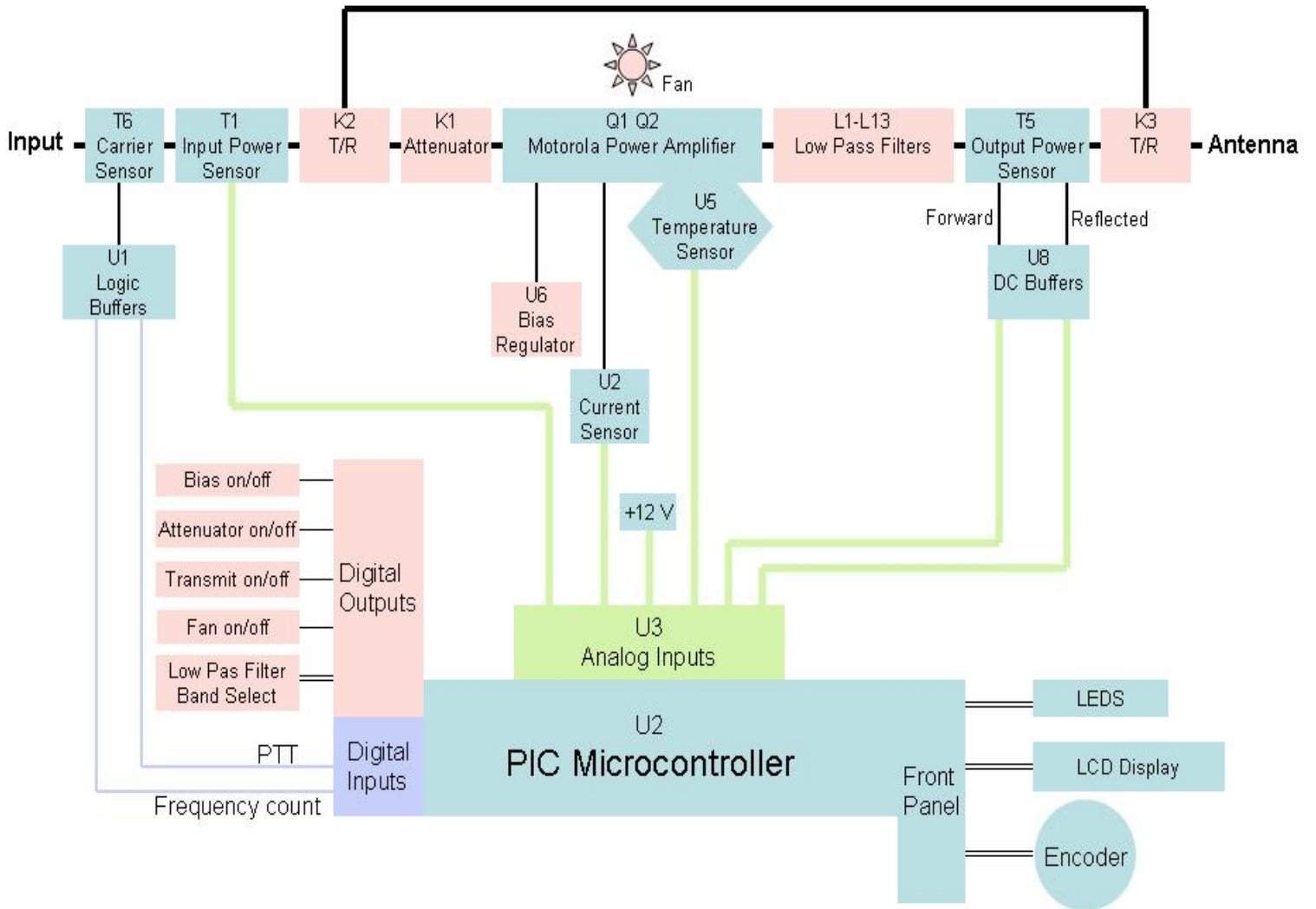

Description of Operation Controls

Conventions:

1. An underline cursor on the screen indicates an item that may be customized. Tapping the button will underline another variable on the same screen. For example the Volts and Amps Screen 9.

[12.0V _0.0A] Tap the switch [12.0V 0.0A] to see the cursor position change.

2. Rotate the knob CW or CCW for additional screens. There are 10 screens total.
3. Press/Hold to modify an item. The underline cursor becomes a flashing cursor indicating that the item can now be modified. Rotate the knob right to increase a choice. Rotate the knob left to decrease a choice. Tap the button to end data entry. The changes are stored in non-volatile memory.

From Power on, there is a four second start up screen: [HFSP PRO V 4.02B] This screen persists for 4 seconds before showing the 1st of 10 screens. This screen identifies the software version level. After 4 seconds you see: [AMP is Bypassed]

Screen 1

AMP Control

[AMP is Bypassed] The amp is bypassed. Tap the button and screen changes to: [AMP is On-Line] This message indicates the amp is now On-Line but not Ready. To make the amp Ready, a minimum of a 1W carrier for the band of choice is required to properly set the Low Pass Filter.

1. Press the CW or TUNE key on the transceiver on your band of choice.
2. After about 5 seconds, the message will change to [AMP is Ready] indicating that the AMP has selected the correct LP Filter.
3. Release the CW or TUNE key. The appropriate filter band relay will select. Confirm that the proper band filter has been selected.
4. The amp is now ready for operation on your current band.
5. If you change bands, you must tap the button to revert back to the [AMP is Bypassed] message in order for the low pass filter selection to select to function.
6. In the Bypass position, you can operate QRP since the amp is bypassed.

7. You can switch from Ready to Standby without having to go through the process of setting the LP filter again.
8. From Ready state: Press/Hold the button for a second then release. The amp changes to the Standby state. The ON led is not lit indicating you are now in standby (QRP mode).
9. From Standby state: Press/Hold the button for a second then release. The amp changes back to the Ready State. The ON led is lit indicating you are now ready to amplify.

Screen 2

Temperature and Status Screen

There are no adjustments on this screen. The temperature is the temperature of the heat sink. The Status is temperature status (normal, warm or hot). [31 C Normal]

- Normal: The fan comes on at 45 degrees C and goes off at 38 degrees C
- Warm is display when the temperature exceeds 80 degrees C, a warning level.
- Hot is displayed when the temperature exceeds 90 degrees C. Upon HOT, the AMP will terminate TX, switch to Standby and light FAULT.
- To recover, allow the unit to cool down before activating the AMP again.

Screen 3

Power In and Power Out Screen

Power In is designated Pi and Power Out is designated Po. This screen updates each second. Characteristics of this screen are listed below.

- The reading displayed is the average of the last one hundred 10ms reads. The value is very stable and steady for a constant input such as a CW carrier. A SSB signal with the peaks and valleys will display a one second average value for the waveform.
- Calibration is multipoint. There is a calibration parameter for each filter band for both the power in and power out readings.
- Cursor positions: [Pi 3.1w Po 97w] or [Pi 3.1w Po _97w] focus depending upon the tap of the button. (note the position of the underline character)

Power In Calibration

1. Set the filter band before proceeding. See Screen 1 and reference Screen 8 for procedure.
2. You must know what your power in reads. Attach a Power meter and a Dummy Load as your calibration setup. Record your Power In reading.
3. Press/Hold the button while the underline cursor is selecting the Pi reading. The underline cursor will become a flashing cursor. Release button.
4. Key the Transceiver.
5. Adjust the Screen 3 Pi reading by turning knob CW or CCW to make it agree with your watt meter reading.
6. Tap the button to lock in your calibration for this band. The flashing cursor will be replaced with an underline cursor.
7. Un-key the transceiver. The calibration information for the current band will be saved in non-volatile memory.

Power Out Calibration

1. Make the AMP Ready (see Screen 1) and then return to Screen 3.
2. Tap the button to move the cursor to the Po watts reading position on the screen. You have now selected Po for calibration.
3. Press/Hold the button while the underline cursor is selecting the Po reading. The underline cursor will become a flashing cursor. Release button.
4. Key the transceiver. The Po reading should show a power out reading. The external watt meter should display a watts reading.
5. Adjust the Screen 3 Po reading by turning knob CW or CCW to make it agree with your watt meter reading.
6. Tap the button to lock in your calibration for this band. The flashing cursor will be replaced with an underline cursor.
7. Un-key the transceiver. The calibration information for the current band will be saved in non-volatile memory.
8. Repeat this procedure for other bands of interest.
9. Note that the LED Bar graph is updated 100 times per second and displays the peak value rather than the average. The bars displayed decrements 100Watts/second in

the absence of signal. This function allows the bar graph to follow the peaks and valleys of a SSB transmission. The LCD screen displays a one second average of the readings instead of peak readings.

10. The pulsating bar graph display is a result of the rapid refresh rate.

Screen 4

Power Reflected and SWR Screen

This screen displays the Power Reflected (Pr) and the Standing Wave Ratio (SWR). The Pr value can be calibrated in the same manner as the Pi or Po readings. Characteristics of this screen are:

- The SWR is a calculation where: $SWR = (1 + (\text{SQR}(\text{Pr}/\text{Po}))) / (1 - (\text{SQR}(\text{Pr}/\text{Po})))$
(SQR=square root)
- A SWR reading of 1.2 on the screen 3 is an abbreviation for a 1.2:1 ratio. The AMP continually monitors and reports the SWR by calculation using Po and Pr readings.

Calibration of Pr and SWR Limit [Pr 0.0w SWR 0.0]

- Note that SWR is not calibrated on Screen 3 but you can adjust the SWR Limit.
1. Tap the cursor to move the underline to the SWR value.
 2. Press/Hold to change the cursor to flashing. The value displayed is the SWR Limit that you impose on the amp for normal operation. A value of 2.0 - 3.0 is typical. No TX is required to make this adjustment.
 3. Rotate the button to the desired value. Tap the button to lock in the change.
 - The SWR Limit functions in the following manner:
 - If the AMP is programmed for AUTO Attenuator the SWR Limit will switch in the attenuator if the SWR exceeds the SWR Limit. If the Attenuator is already switched in, the amp will terminate TX and go to Bypassed state. The SWR and FAULT LEDs will light.
 - If the Attenuator is set for always OFF or always ON, no attenuator action will occur. However the SWR and FAULT LEDs will light and the AMP will switch to Bypassed.

Screen 5

Gain and Frequency Screen (Gn and F)

This is a diagnostic screen that calculates the Gain (ratio of P_o/P_i expressed in dB power) and measures the Frequency of the TX drive signal.

- Note a cursor position for the Frequency F. This implies that you can calibrate the frequency reading. There is a single point calibration variable to correct for slight differences in clock rates.

Calibration of Frequency

Select a mid band such as 20M as your frequency of reference.

You can make this calibration in the AMP Bypassed position.

Note the frequency of the transceiver. This will be your target frequency for adjustment.

1. Tap the button to get a flashing cursor.
2. Key the transceiver with at least 1W drive.
3. Turn the knob CW or CCW to get a reading as close to the transceiver frequency as possible. Please note that the resolution of measurement will not let you get any closer than about 10Khz.
4. Tap the button to end the procedure.
5. Do not expect an accurate reading with SSB signals.

Use of frequency measurement in the AMP

- A range of frequencies (KHz) is used to determine which filter to use.

BAND	START	END
160	1536	2560
80	2560	4608
60/40	4608	8192
30/20	8192	14336
17/15	14336	22528
12/10	22528	30200

This chart shows the Start and End frequencies (KHz) for a particular band range.

Screen 6

Hold Time in Seconds (Ts) for CW and SSB modes

You can enter a value for both CW and SSB that the AMP uses as a hold time before turning off the TX control signal after a loss of drive. As long as carrier (CAR signal) is present, the HoldTime will not decrement. Granularity is 0.01seconds.

Set Hold Time for CW [Ts 0.05 now CW]

1. Tap button to move the Underline cursor under the Ts value (left).
2. Press/Hold button to change the cursor to a flashing cursor.
3. Rotate the button to change the hold time for CW.
4. Tap Button to lock in new value for CW hold time.

Change Mode from CW to SSB [Ts 0.05 now CW]

1. Tap button to move cursor to the mode position (where current mode is underlined).
2. Press/Hold button to change the cursor to a flashing cursor.
3. Rotate the button to select SSB.
4. Tap button to lock in the choice.
5. The current hold time for SSB is displayed.

Set Hold Time for SSB [Ts 0.15 now SSB]

1. Press/Hold button to change the cursor to a flashing cursor
2. Rotate the button to change the hold time for SSB.
3. Tap Button to lock in new value for SSB hold time.

Screen 7

TX Control and Attenuator Mode Control

Use this screen to manually turn the TX On/Off without RF drive. This is the control used to adjust the bias current for the output transistors.

[TX Off ATN Auto] and [TX Off ATN Auto] (note cursor positions)

Control TX

1. Tap the button to place the Underline cursor to the TX Off position.
2. Press/Hold button to change the cursor to flashing.
3. Rotate the knob to either ON or OFF. The AMP will respond as you rotate the choice.
4. Make your Bias adjustment.
5. Rotate the knob back to the OFF position.
6. Tap the button to return to an underline cursor.

Control ATN (Attenuator)

The Attenuator can be set for ON, OFF or AUTO at your discretion. If you are operating with drive below 3W you can use the attenuator as a type of amplifier “fold back” limiting based on SWR conditions. If you are operating with more than 3W drive, the Attenuator will be automatically inserted in the AUTO mode. You can disable the Attenuator by using the OFF position.

1. Tap the button to place the Underline cursor at the ATN Auto position.
2. Press/Hold button to change the cursor to Flashing.
3. Rotate the knob to either ON OFF or AUTO. The AMP will respond after you tap the button to return to an underline cursor.

4. The amplifier, in the Auto position, will decide whether to use the attenuator as the AMP becomes Ready. The attenuator will not switch in or out during a transmit cycle. This function is useful to handle a wide range of transceiver drive levels.

Screen 8

There is an option to set the Filters under Manual Control or Auto Control.

Manual Filter Control

If you are operating with manual filter selection, there is no filter choice to make by the AMP. That decision is for the user to make. **Improper filter choice by the user can lead to interference and possible damage to the filter module and amplifier transistors. Use manual control of the low pass filter with due caution.**

1. Before operating with the AMP, manually select the filter choice. The Filter Mode must be MAN (manual) in order to manually control the filter choices. Screen 1 functions as described below in the Manual Mode:
 - a. Tap the button while displaying Screen 1 [AMP is Bypassed]. The message changes to [AMP is Ready].
 - b. Tap the button again to switch to [AMP is Bypassed].

This screen displays or controls the Low-Pass Filter. The control can be Manual (MAN) or Automatic (Auto). In the Automatic Mode, the AMP decides what band to set the filter to when the AMP is switched from Bypassed to On-Line and a CW carrier of at least 1W is transmitted. The AMP does not transmit while making the Filter Selection. When the Filter is determined by measurement of the frequency with sufficient drive, the AMP status will switch to Ready. After the AMP is Ready, a drive signal will be amplified.

[F 17/15 F Auto] or [F 17/15 F Auto] (note cursor positions)

This screen lets you set the filter by hand to a particular band. This function is useful for confirmation of wiring and control. The Relays will click and the appropriate Filter LED indicator will light as you rotate through the choices. You can test the filter choice selections in either Auto or Manual mode.

Filter Selection Control

1. Tap the button to place the Underline cursor at the F 17/15 position (or current position).

2. Press/Hold button to change the cursor to Flashing.
3. Rotate the Knob to cycle through the filter choices. You will hear the relays click and see the LED indicator for the filter band change. This is a good diagnostic tool during initial testing.

Filter Mode Selection Control

1. Tap the button to place the Underline cursor at the F Auto position.
2. Press/Hold button to change the cursor to Flashing.
3. Rotate the Knob to switch from Auto to Man or Man to Auto.
4. The Man position could be very useful if the user of the transceiver cannot easily perform a tune function or infrequent band changes are contemplated.

Screen 9

Volts and Amps Display.

This screen displays the DC input Volts and the current of the power transistors when the AMP is transmitting.

There is an underline cursor for the Volts and the Amps

[11.6V 0.0A] and [11.6V _0.0A] (note the cursor positions)

You can calibrate the volts and amps to match an external meter.

Voltage Calibration

1. Tap the button to place the Underline cursor at the Volts position.
2. Press/Hold button to change the cursor to Flashing.
3. Rotate the Knob to change the volts reading to match the external meter.
4. Tap the knob to lock in the calibration.

Amps Calibration

1. Tap the button to place the Underline cursor at the Amps position.
2. Press/Hold button to change the cursor to Flashing.
3. Briefly activate the transmitter with a CW signal.

4. Rotate the Knob to change the current reading to match the external meter.
5. Tap the knob to lock in the calibration.

The AMP has a test for low voltage (<11.5V) and high current (>18A average) that will cause the AMP to light the AMP (warn) LED while the condition exists.

Screen 10

[End Menu Go Left]

This screen prompts the user that there are no more screens. Rotate CCW. Note: Using a fixed stop instead of a circular menu idea provides better orientation of where you are in the menu system.

Factory Reset

You can return to the factory settings by Press/Hold of the knob while you turn the power on.

You will return to factory settings if you install a new chip or reprogram an old chip.

Please address comments or suggestions to Virgil Stamps at vstamps@comcast.net